

## DIAPHRAGM INSTRUMENTS



Differential Pressure Plus, Inc. Supplies quality differential pressure instruments designed to measure the difference in pressure between two points in a system and show it on a single dial instrument. A magnetic movement senses the differential pressure. The instrument has separate pressure and indicating chambers.

These diaphragm instruments can indicate small values of differential pressure even when used at high line pressures. They provide instantaneous and continuous information regarding system conditions helping in eliminating premature servicing of equipment, avoid unscheduled down time of costly processes and detect abnormal system conditions.

**Switching Facility :** Instruments can be supplied with reed switches to initiate alarms, activate other equipment, or shut the system down. Two switches are used when high and low limits are desired. Gauge-switch models provide the user with both, gauge readout and switch operation.

### APPLICATIONS :

Monitor filter conditions, set filter by-pass, or initiate filter cleaning cycle. Determine obstructions in process lines. Check condition of pumps, heat exchangers, and other processing equipment. Detect abnormal and reverse flow conditions. Measure flow rates with venturi, orifice, or pitot tube. Balance and adjust flow rates in piping system. Monitor liquid levels in tanks.

## 300 DGC

### Small Convolved Diaphragm Instruments

### SALIENT FEATURES

- Cost effective and reliable.
- Simple and compact design.
- Easy to read dial gauge eliminates the accumulated errors of two instrument installations.
- **Working pressure up to 100 bar.**
- **Differential pressure range up to 4bar.**
- Adjustable reed contact switching.
- Indicating mechanism isolated from pressure chamber.
- Wide applications in air, gas and liquid media.
- Zero migration between high and low pressures.
- Only switch is also available.
- Manufactured in ISO 9002 certified plant.
- Exported worldwide.



### Differential Pressure Plus, Inc.

16 Carriage Hill Drive  
Branford, CT 06405

Phone : 203-481-2545

Fax : 203-483-7169

Email : [DPGauge@AOL.com](mailto:DPGauge@AOL.com)

Website : [www.differentialpressure.com](http://www.differentialpressure.com)

## MAGNETIC PRINCIPLE

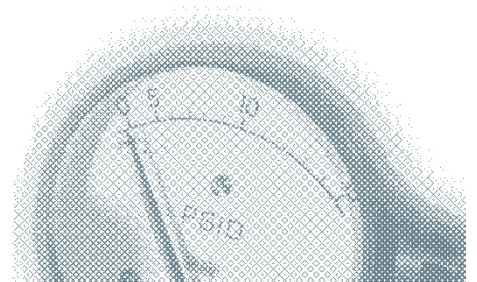

## OPERATING PRINCIPLE

High and Low pressures are separated by a sensor assembly consisting of a magnet, diaphragm, and a range spring. The difference in pressure causes the sensor assembly to move in proportion to the change against a range spring.

A rotary magnet, located in a separate body cavity and isolated from the acting pressures, is rotated by magnetic coupling as per the linear movement of the sensor assembly. A pointer attached to the rotary magnet indicates differential pressure on the dial.

**Switch** : Reed switches are located adjacent to the pressure chamber and are activated by the magnetic field of the sensor assembly

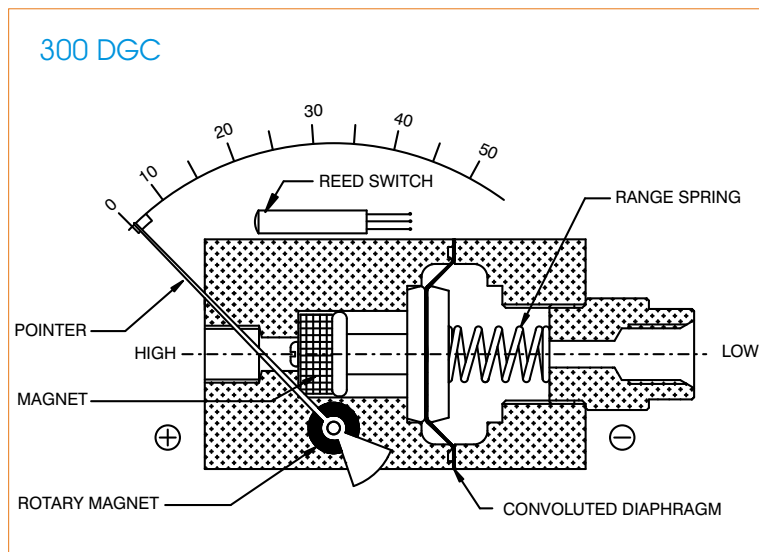

## TECHNICAL DATA

### Specifications

Accuracy	: $\pm 2\%$ of the FSD (Ascending)
Migration	: No migration, Zero leakage from high to low port
Range	: 0-0.75 to 0-4 bar or equivalent range in other units
First marking on the scale	: 15% of the FSD
Sensing element	: Diaphragm
Wetted parts	: Diaphragm, Body material, SS 302 spring & ceramic magnet
Case material	: Stainless steel (SS 304)
Dial size in inch /mm	: 2.5", 3.5", 4", 4.5", 6" / 63, 80, 100, 115, 150
Mounting	: Direct, front flange & 2" pipe mounting
Max. working pressure	: 100 bar / 1500 psi.
Max. process temperature	: 80° C / 175° F
Body material	: Aluminum, Brass, SS 316
Seals	: Buna-N, Viton & EPDM diaphragm & 'O' rings
Window	: Float glass (Std.), toughened glass, acrylic glass & safety glass on request.
Connection	: 1/4" NPT(F) Std. optional 1/4" BSP(F) with adaptor on high side.
Porting	: In-line, rear, bottom, bottom & vent, Inline & vent, Inline & botom.
Over range protection	: Up to the max. working pressure from high side.
Protection for gauge & switch	: IP 65 / NEMA-4

### Options

Glycerine filling  
 Red follower pointer (except 2" & 6")  
 Customer logo  
 Dual scale  
 Colour band  
 Filter mesh in (+) connection  
 Descending calibration

### Switches (Adjustable in 30-100% of FSD)

1 or 2 SPSTs with a DIN plug  
 1 or 2 SPSTs with a terminal strip  
 1 SPST with a built in relay  
 1 or 2 SPDTs with a terminal strip  
 1 or 2 SPDTs with a DIN plug

## STANDARD DIMENSIONS (MODEL 300 DGC)

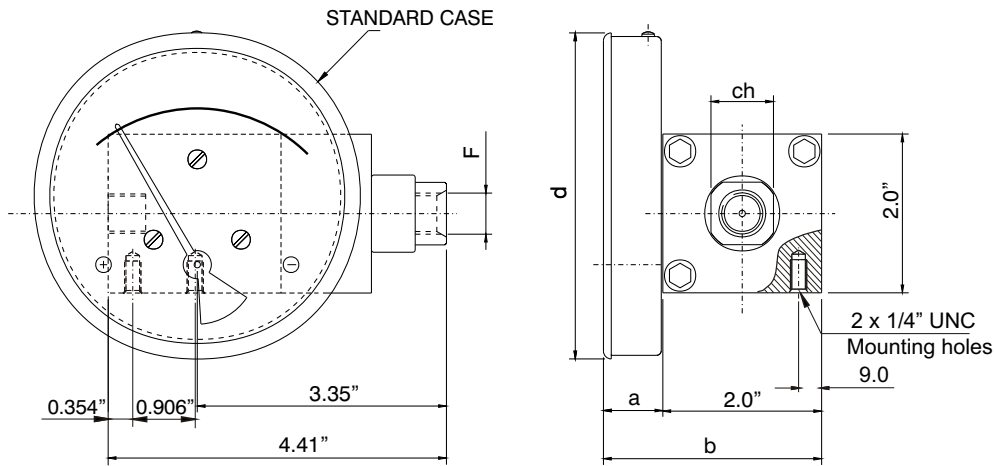

DN	F	a	b	d	ch
2.5"	1/4" NPT	0.75"	2.75"	2.59"	0.75" SQ.
3.5"	1/4" NPT	0.75"	2.75"	3.26"	0.75" SQ.
4.0"	1/4" NPT	0.75"	2.75"	4.10"	0.75" SQ.
4.5"	1/4" NPT	0.75"	2.75"	4.71"	0.75" SQ.
6.0"	1/4" NPT	0.75"	2.75"	6.07"	0.75" SQ.

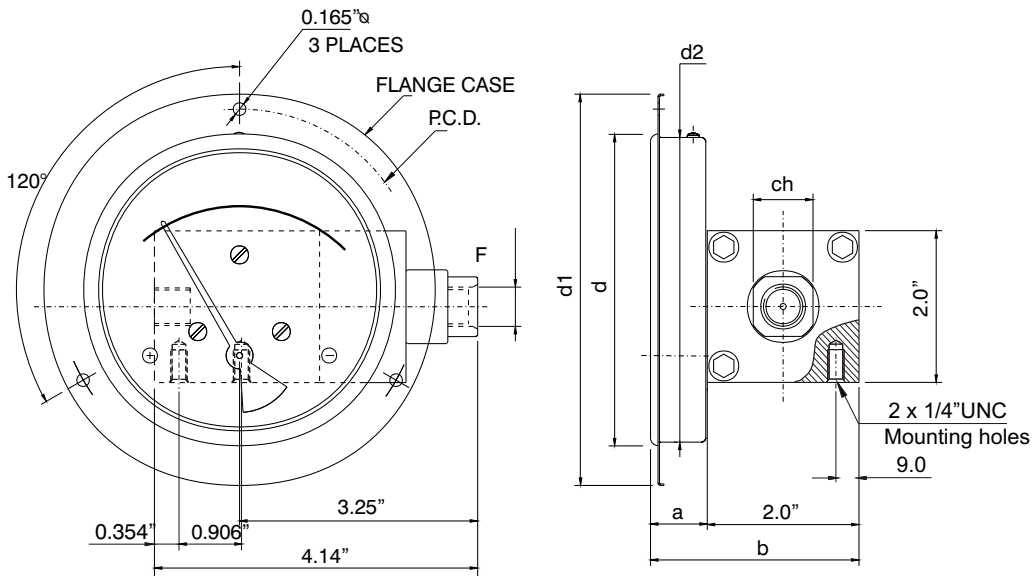

DN	F	a	b	d1	d2	ch	p.c.d.	d *
2.5"	1/4" NPT	0.75"	2.75"	3.66"	2.55"	0.75" SQ.	3.26"	2.59"
3.5"	1/4" NPT	0.75"	2.75"	4.29"	3.22"	0.75" SQ.	3.89"	3.26"
4.0"	1/4" NPT	0.75"	2.75"	5.15"	4.01"	0.75" SQ.	4.76"	4.10"
4.5"	1/4" NPT	0.75"	2.75"	5.74"	4.60"	0.75" SQ.	5.35"	4.71"
6.0"	1/4" NPT	0.75"	2.75"	7.12"	6.0"	0.75" SQ.	6.73"	6.07"

\* PANEL CUT OUT = d + 0.04"

**GAUGE + SWITCH WITH REED CONTACTS WITH DIN PLUG AND TERMINAL STRIP  
(MODEL DPH200S)**

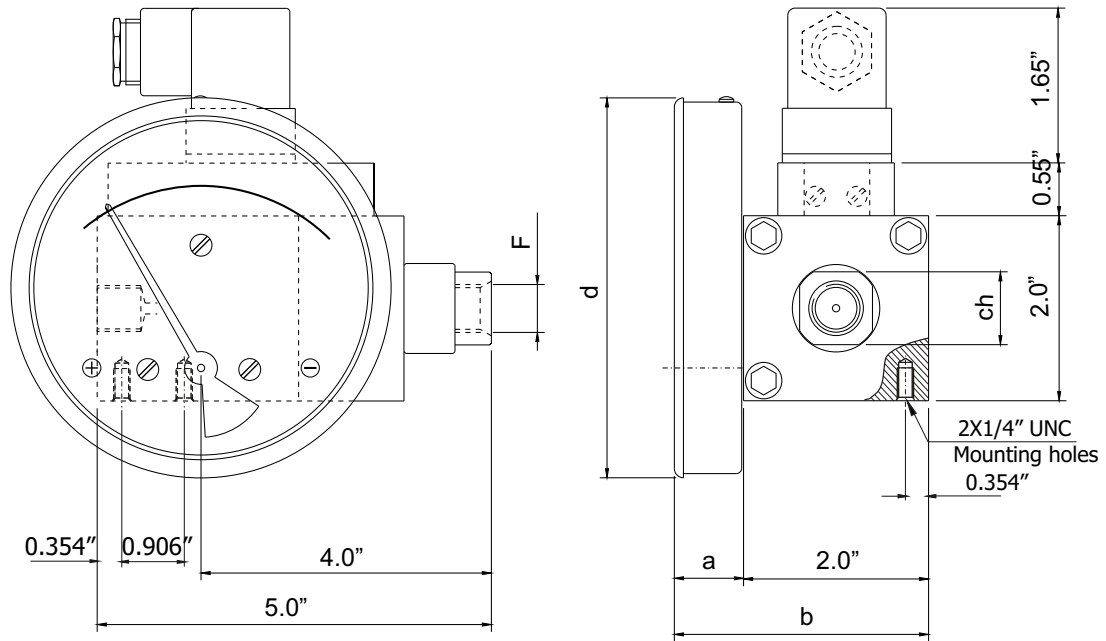

DN	F	a	b	d	ch
2.5"	1/4" NPT	0.75"	2.75"	2.59"	0.75" SQ.
3.5"	1/4" NPT	0.75"	2.75"	3.26"	0.75" SQ.
4.0"	1/4" NPT	0.75"	2.75"	4.10"	0.75" SQ.
4.5"	1/4" NPT	0.75"	2.75"	4.71"	0.75" SQ.
6.0"	1/4" NPT	0.75"	2.75"	6.07"	0.75" SQ.

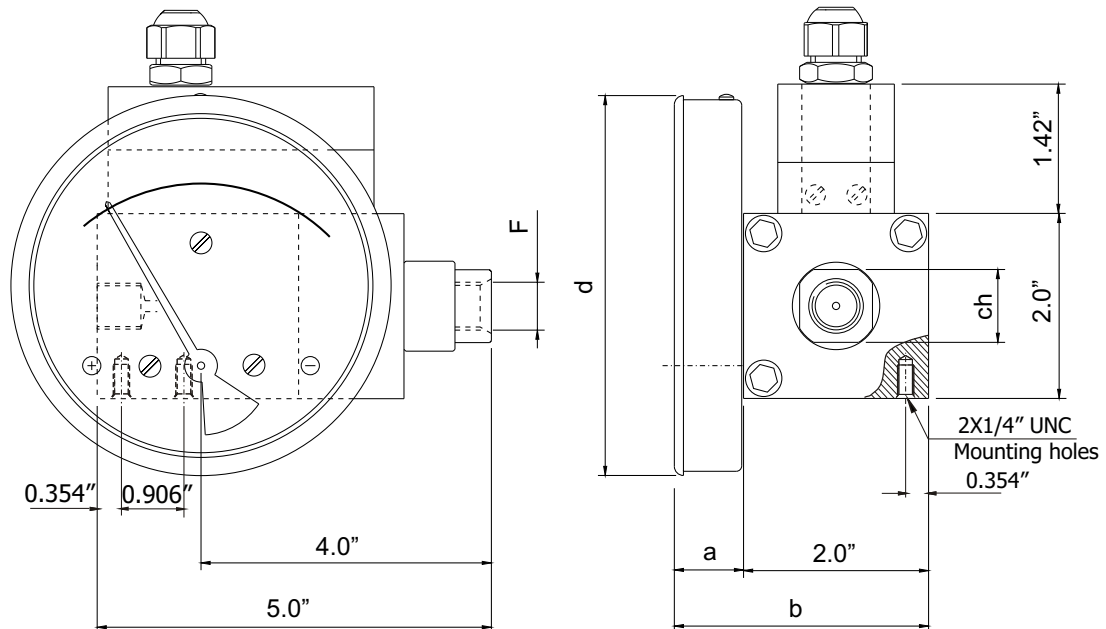

**GAUGE + SWITCH WITH REED CONTACTS WITH TERMINAL STRIP & 1/2" NPT CONDUIT CONNECTION (MODEL DPH200S)**

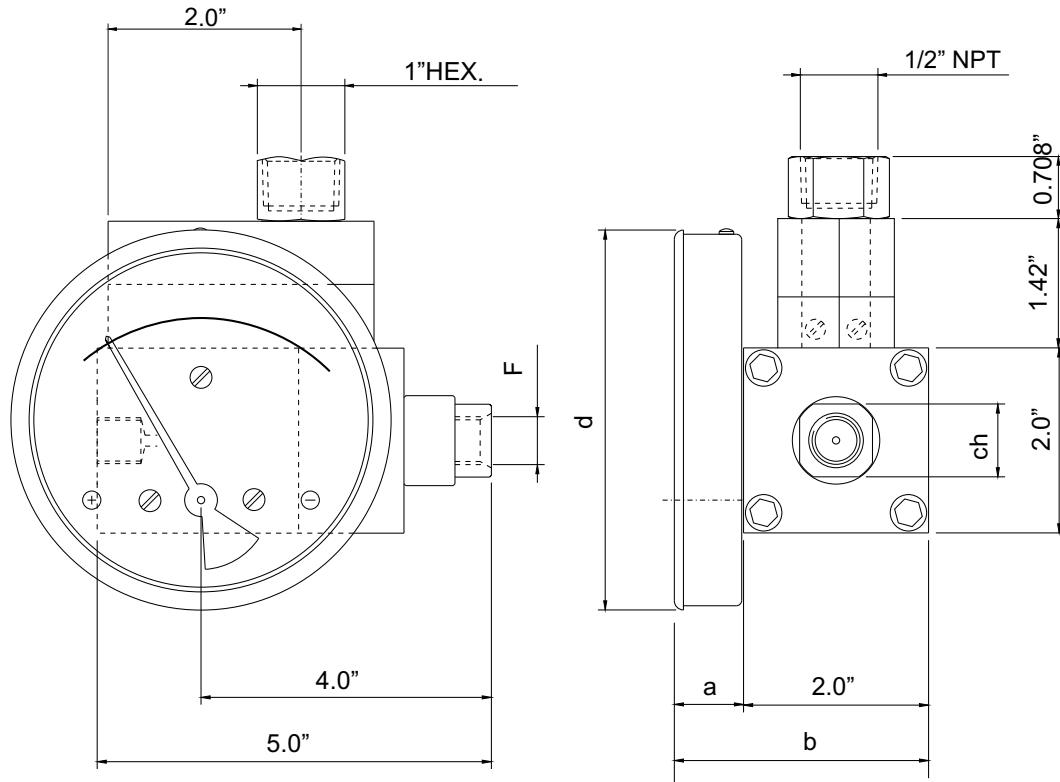

DN	F	a	b	d	ch
2.5"	1/4" NPT	0.75"	2.75"	2.59"	0.75" SQ.
3.5"	1/4" NPT	0.75"	2.75"	3.26"	0.75" SQ.
4.0"	1/4" NPT	0.75"	2.75"	4.10"	0.75" SQ.
4.5"	1/4" NPT	0.75"	2.75"	4.71"	0.75" SQ.
6.0"	1/4" NPT	0.75"	2.75"	6.07"	0.75" SQ.

# HOW TO ORDER A DIFFERENTIAL PRESSURE INSTRUMENT, MODEL 300 DGC

## Example Code Descriptions

	G	Gauge			
	S	Switch			
	GS	Gauge + Switch			
	A	Aluminium ( <i>anodized semi hard</i> )			
	B	Brass			
	S	SS-316			
	2.5	2.5" (63 mm)	4.5	4.5" (115 mm)	
	3.5	3.5" (80 mm)	6.0	6.0" (150 mm)	
	4.0	4.0" (100 mm)			
	4B	¼" BSP (Female)			
	4N	¼" NPT (Female)			
	ZZ	Special connection sizes using adaptor			
	1	In-line (Standard)			
	2	Rear / Back			
	3	Bottom			
	4	Bottom & Vent			
	5	Inline & Vent			
	6	Inline & bottom			
	SS	SS 304 with a rubber ring (standard)			
	SF	SS 304 flange with a rubber ring (standard flange)			
	F	Glass (standard)			
	A	Acrylic			
	T	Toughened glass			
	L	Safety glass			
	B	Buna-N (standard)			
	V	Viton			
	E	EPDM			
	0	None			
	1	One SPST, with a DIN plug*			
	2	One SPST, with a terminal strip			
	2A	One SPST, with built in relay			
	3	Two SPSTs, with a DIN plug*			
	4	Two SPSTs, with a terminal strip			
	5	One SPDT, with a DIN plug*			
	6	One SPDT, with a terminal strip			
	7	Two SPDTs, with two DIN plugs*			
	8	Two SPDTs, with a terminal strip			

**SPST Specifications :**  
 10 VA AC or DC (max)  
 100 V AC or DC (max)  
 0.5 Amp AC or DC (max)

**SPDT Specifications :**  
 3 VA AC or DC (max)  
 30 V AC or DC (max)  
 0.30 Amp AC or DC (max)

**Built in relay :**  
 230 V AC, 1 Amps.

\* **DIN plug** : we mount it on the top, on the plastic switch cover. However we can give it at the back as a request.

Switch applicable for "S" & "GS" types only. Switches operate from 30 to 100% of the range & mounted at the back. Switches are in a plastic enclosure, they are factory set, field adjustable.

Kg/cm <sup>2</sup>	0.075	0.25	-	0.5	0.75	1	-	1.6	2	2.5	3	-	4
bar	0.075	0.25	-	0.5	0.75	1	-	1.6	2	2.5	3	-	4
Mbar	75	250	-	-	750	-	-	-	-	-	-	-	-
psi	1	-	5	8	-	15	20	25	30	-	40	50	60
kPa	-	25	-	50	75	100	-	160	200	250	300	-	400

Other ranges on request.

	0	None			
	A	Glycerine*			
	B	Red follower pointer on acrylic window*			
	C	Customer Logo			
	D	Dual scale			
	E	Colour band			
	F	Strainer in (+) connection			
	H	Descending calibration ( <i>Long delivery time</i> )			
	N	NACE			
	S	Silicone oil*			

\* Affects accuracy

### Ordering Sequence Code (Example)

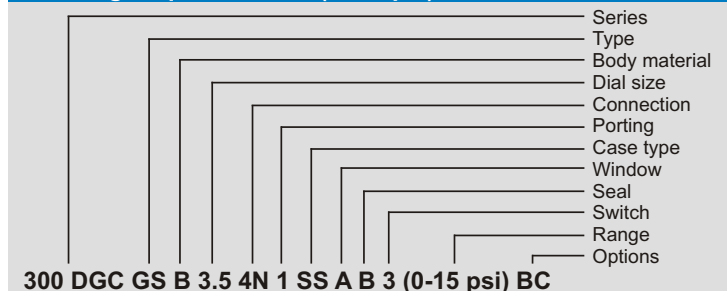

300 DGC GS B 3.5 4N 1 SS A B 3 (0-15 psi) BC

### Limitations for making combinations:

- Glycerine filling will not have follower pointer.
- No follower pointer available in 6" (150 mm).

Specifications and dimensions given in this leaflet represent the state of engineering at the time of printing, modifications may take place and materials specified may be replaced by others without prior notice.