



Differential Pressure  
Plus Inc.  
Branford, CT, U.S.A



# DPP175 Indicator

website: [differentialpressure.com](http://differentialpressure.com)

email: [info@dpgaugeusa.com](mailto:info@dpgaugeusa.com)

phone: 203-481-2545

# DPP175



*Example Usage*

## **Available Pressure Ranges**

- (8, 15, 22, other upon request)

## **Specs**

Safe to 300 psi

Safe to 150 F

Viton Seals

2 color indicator

Glass filled nylon.

3% accuracy

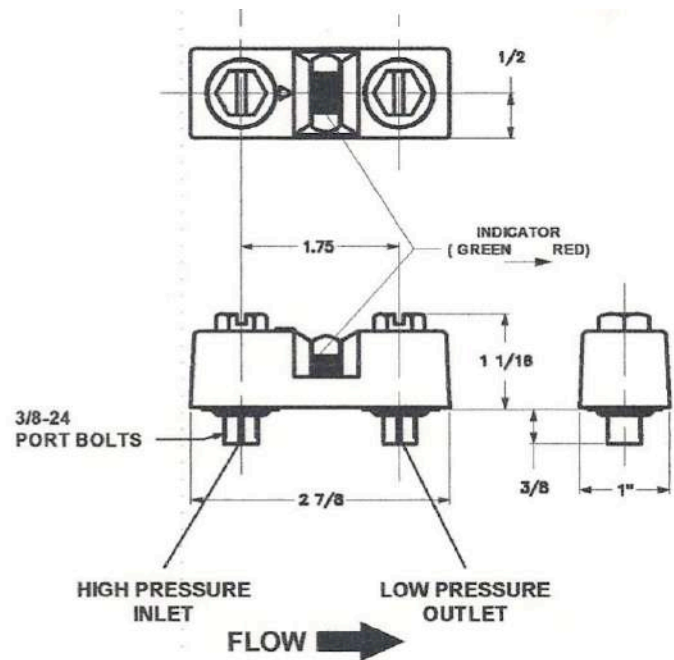

# Interchangeable with DPP975

## Two Solutions

- Manufacturers love our DPP975/ DPP175 product family because of their interchangeability.
- They use the same 1.75" threaded connection to mount on a filter head.
- End users can then choose between indicators at two different price points.





Differential Pressure Plus Inc. has been designing and manufacturing filter indicators and differential pressure gauges for 25 years. With our new company division, LoopMeter, we are now bringing the industry new options for electronic communication. These new designs are sure to bring fresh thinking to the industry.



+

Web: [DifferentialPressure.com](http://DifferentialPressure.com)

Email: [info@dpgaugeusa.com](mailto:info@dpgaugeusa.com)

Phone: 203-481-2545

Address: 67-4 North Branford Road, Branford, CT, 06405