



Differential Pressure
Plus Inc.
Branford, CT, U.S.A



DPP750 Indicator

website: differentialpressure.com

email: info@dpgaugeusa.com

phone: 203-481-2545

DPP750



Example Usage

Available Pressure Ranges

- (8, 15, 22, other upon request)
- Optional switch and base

Specs

Safe to 300 psi

Safe to 150 F

Viton Seals

2 color indicator

Glass filled nylon.

3% accuracy

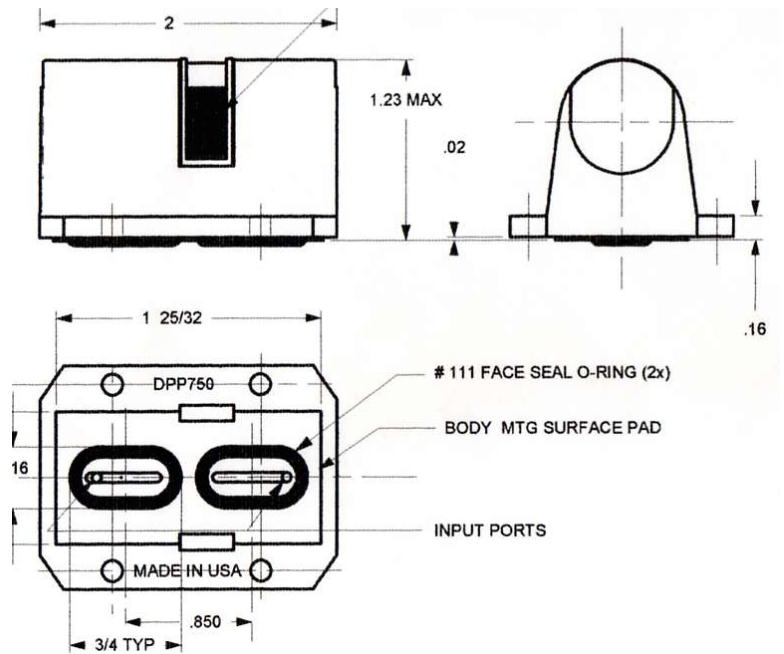

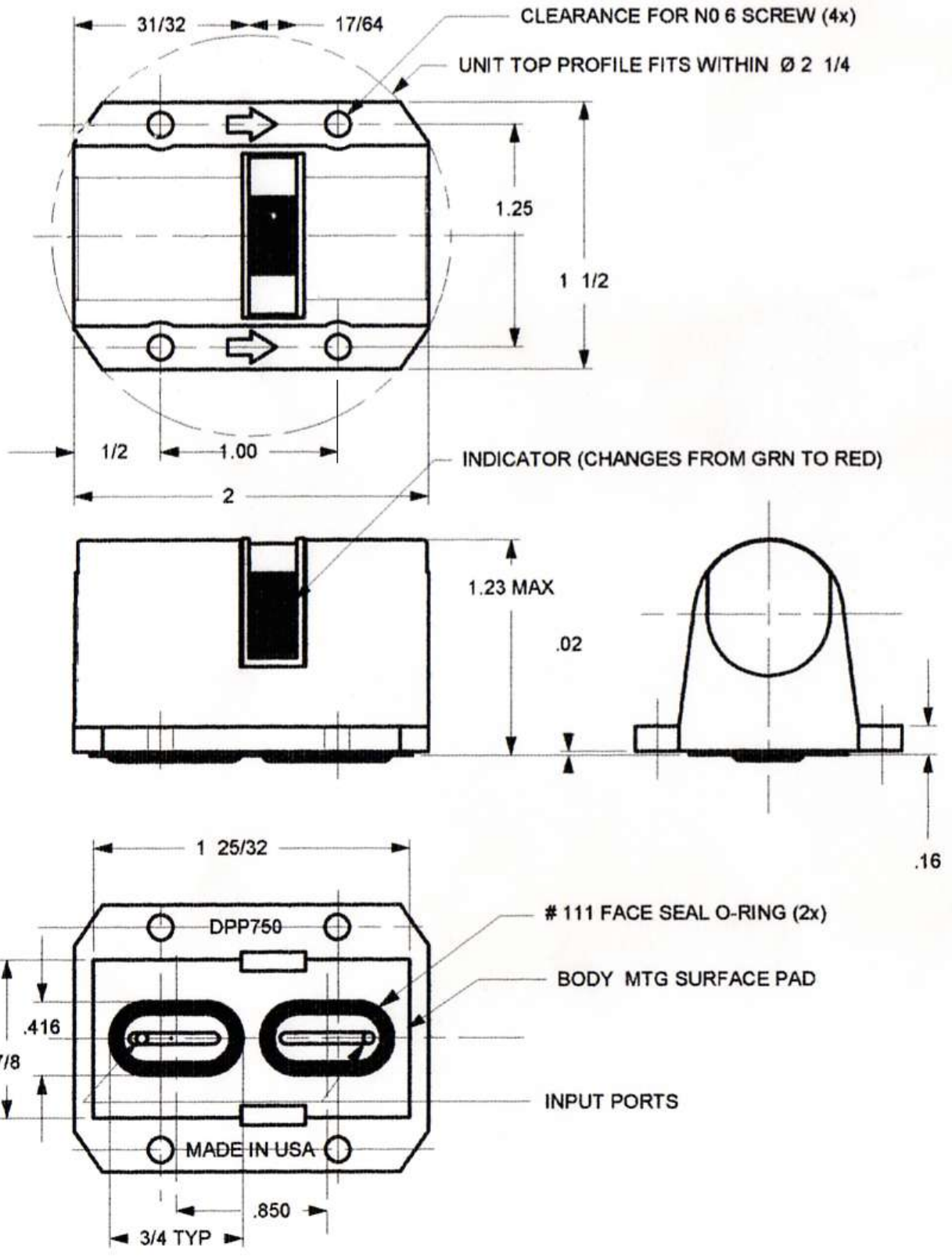

Bases and Switches

Simple and Effective

The DPP750 uses two o-rings and 4 screws to secure it into a filter head. However, it can also be connected to our "mounting base" that supplies 1/8" NPT connections and panel mount ability.

It can also feature an electrical switch that triggers when the indicators turns red.

These options make it great for filters and compressors!

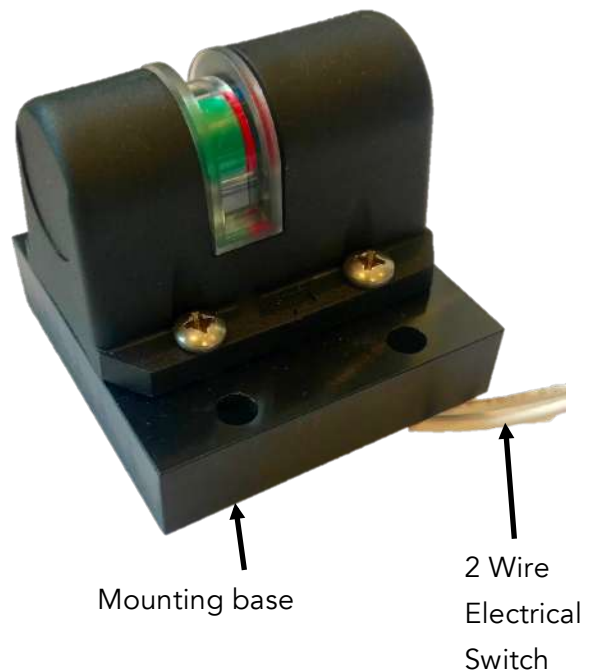



Differential Pressure Plus Inc. has been designing and manufacturing filter indicators and differential pressure gauges for 25 years. With our new company division, LoopMeter, we are now bringing the industry new options for electronic communication. These new designs are sure to bring fresh thinking to the industry.



+

Web: DifferentialPressure.com

Email: info@dpgaugeusa.com

Phone: 203-481-2545

Address: 67-4 North Branford Road, Branford, CT, 06405