



Differential Pressure Plus Inc.

Branford, CT, U.S.A



PG

piston style dp gauge

PG Standard Gauge



Vertical Calibration option with filter vessel mounting kit



Great for carts and other filters

Available Pressure Ranges

- (5 PSID-1,000 PSID)

Specs

- Teflon seal on Piston
- Aluminum, Brass, or Stainless
- Viton Seals or EPDM
- 3,000 PSI system pressure for Aluminum
- 6,000 PSI system pressure for stainless
- SPST Rating 100V/0.5A
- SPDT Rating 30V/0.3A
- Higher Ratings available Upon Request
- 175F Temperature Rating

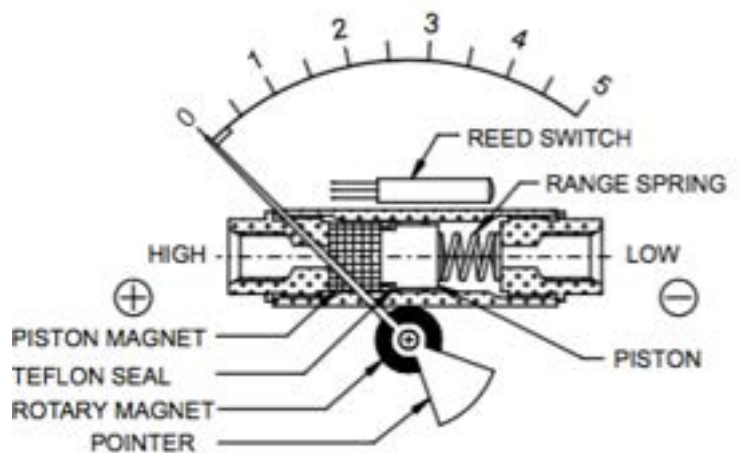

Model Number System

- Standard polymer dial cases come with panel mounting hardware
- Stainless Steel Dial Case option available in panel and non-panel mount
- Specialty pressure ranges available upon request
- Custom Logos are no extra cost



XX - XXXX - XX - XX

Gauge Model	Port Location	Body Material	Dial Face Size	Range	Options
PG: Piston Gauge DG: Diaphragm gauge RDG: Rolling Diaphragm Gauge LDG: Large Diaphragm Gauge	1: Inline 2: Rear 3: Bottom	A: Aluminum B: Brass S: Stainless	25: 2.5" 45: 4.5" 60: 6.0"	#P: PSID #B: Bar #KPA: kPA #IW: in. H2O #mW: mm H2O	CB: Color Band CL: Custom Logo CR: Calibration Report ES: EPDM Seals FP: Follower Pointer LF: Liquid Filling MB: Mounting Bracket OX: Oxygen Cleaning SS: Steel Dial Case SF: Steel Dial Case (Panel Mount)

Examples

Application 1	Application 2	Application 3
Design Requirements <ul style="list-style-type: none"> • Piston Gauge • Inline Connections • Aluminum body with standard Buna seals • 2.5" dial case • 10 PSID range • No Options 	Design Requirements <ul style="list-style-type: none"> • Piston Gauge • Bottom Connections • Aluminum body with standard Buna seals • 2.5" dial case • 2 Bar range • Liquid Fill 	Design Requirements <ul style="list-style-type: none"> • Piston Gauge • Inline Connections • Stainless body with standard Buna seals • 2.5" dial case • 10 PSID • Color Band • 1 SPST switch with terminal strip
Model number <ul style="list-style-type: none"> • PG-1A25-10P 	Model number <ul style="list-style-type: none"> • PG-3A25-2B-LF 	Model number <ul style="list-style-type: none"> • PG-1S25-10P-CBS2

Electrical Switches

S1: 1 SPST w/DIN Plug
 S2: 1 SPST w/terminal strip
 S3: 2 SPST w/DIN Plug
 S4: 2 SPST w/terminal strip
 S5: 1 SPDT w/DIN Plug
 S6: 1 SPDT w/terminal strip
 S7: 2 SPDT w/DIN Plug
 S8: 2 SPDT w/terminal strip

SPST Rating 100V/0.5A SPDT Rating 30V/0.3A

Available Ranges (PSID)	5	10	15	20	30	50	75	100	150
-------------------------	---	----	----	----	----	----	----	-----	-----

Other Units	kPa	Bar	In H2O	mm H2O
-------------	-----	-----	--------	--------

Accessories Overview



Follower Pointer: Shows Max Reading



Color Band: Customizable 3 Color Arc



Mounting Bracket: For Walls or 2" Pipe



Liquid Fill: For Vibration or High Humidity



Standard Polymer Dial Case
(includes panel hardware)



Steel Dial Cases
(Available in Standard or Panel Mount)

SWITCH SETTING

Please follow these instructions when your differential pressure instruments are supplied with switch. The switches are normally factory set to save time at customer's end. However they are field adjustable.

CAUTION : Supply should not exceed switch rating. For higher supply, use of relay circuit is recommended.

SWITCH ADJUSTMENT

Switch adjustment screw is located on plastic cover.

Rotate the screw anti-clockwise to increase the set point and clockwise to decrease the set point.

One or two trials may be necessary to attain the exact set point.

Above procedure to be followed by putting the instrument on test bed or while in actual service.

NOTE : Instrument and switch has IP65 protection. PG7 or PG 9 glands provided for cables. Use cable sizes dia 3 to 6.5 mm and dia 4 to 8 mm respectively.

This model is **CE** certified.

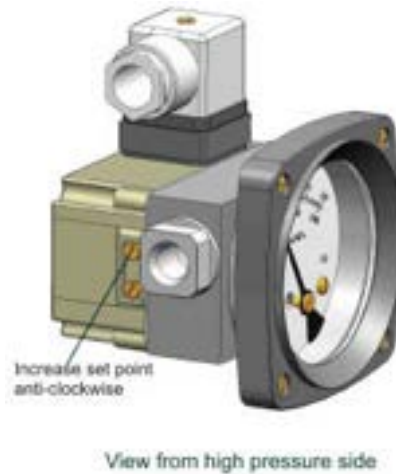

SPST SWITCH

Specifications

Switches are provided as per customer requirement. Please refer gauge label for switch specification.

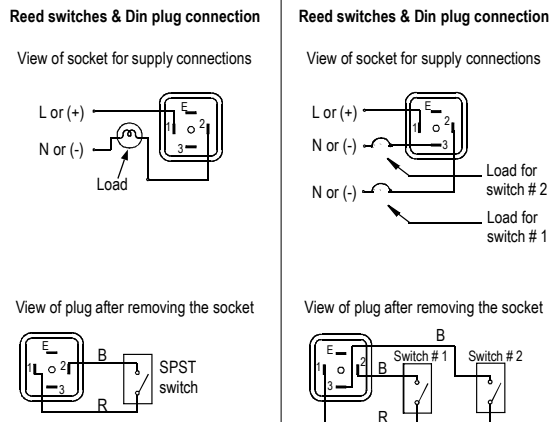
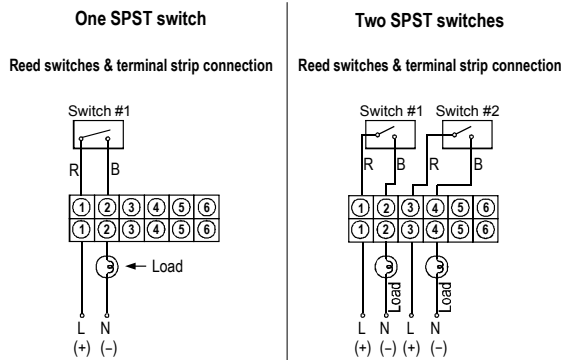

SPDT SWITCH

Specifications

Switches are provided as per customer requirement. Please refer gauge label for switch specification.

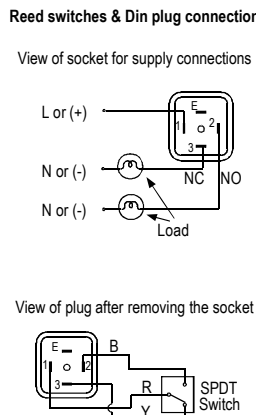
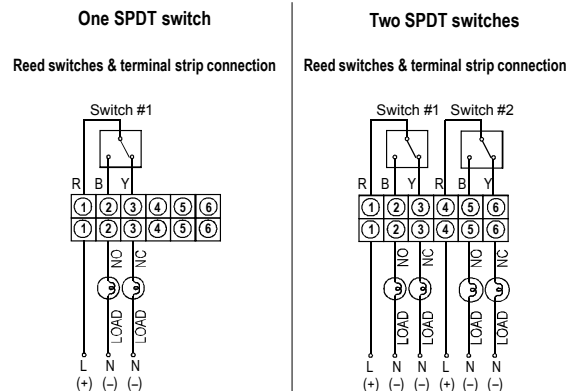

R=Red, B=Black, Y=Yellow, L=Live or +ve supply, N=Neutral or -ve supply
 * Body to be suitably earthed while using gauge + switch and only switch.

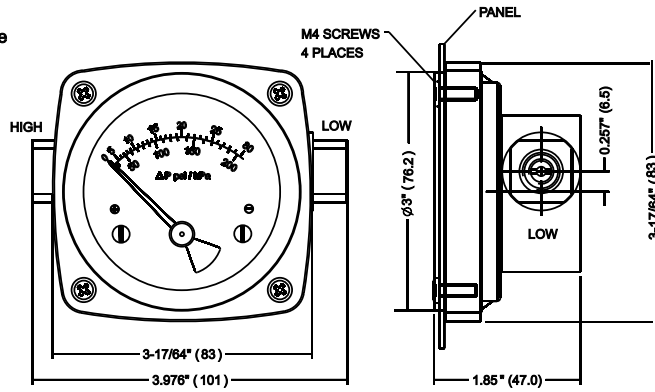
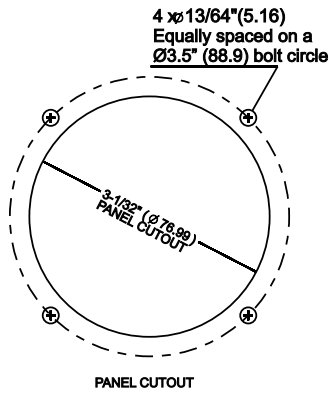

2-1/2" DIAL SIZE

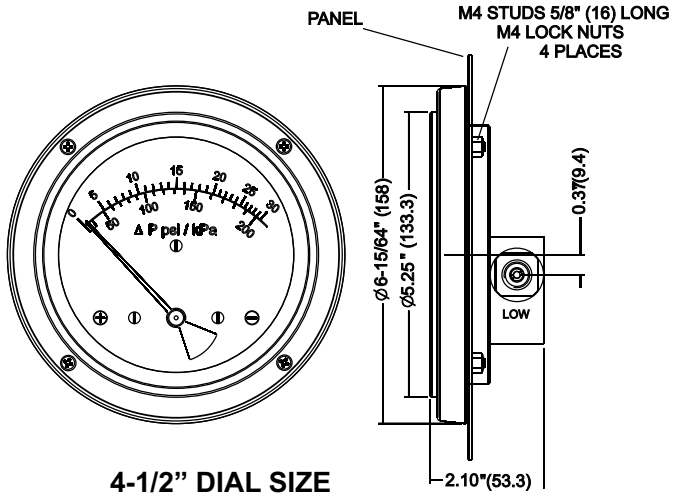
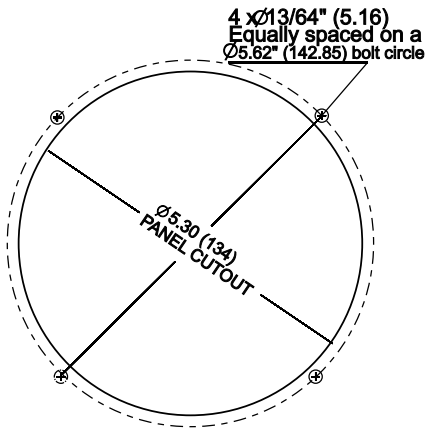

4-1/2" DIAL SIZE

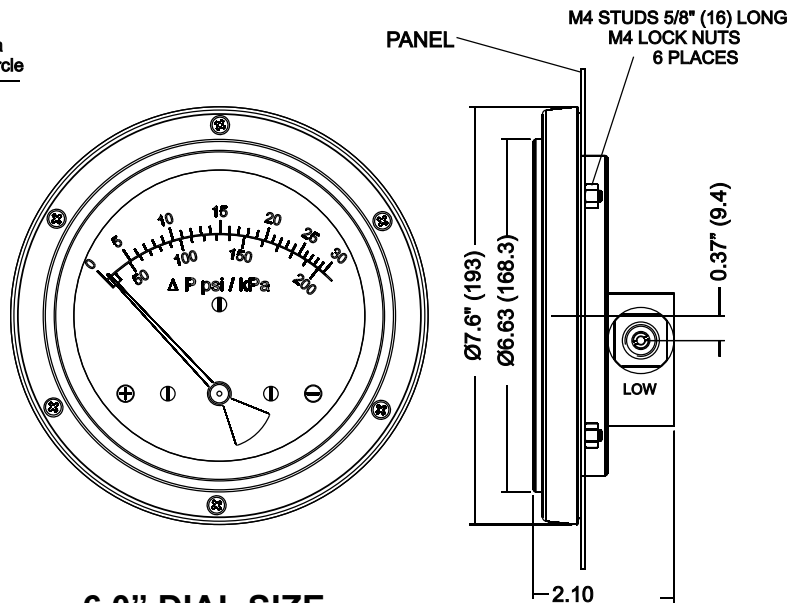
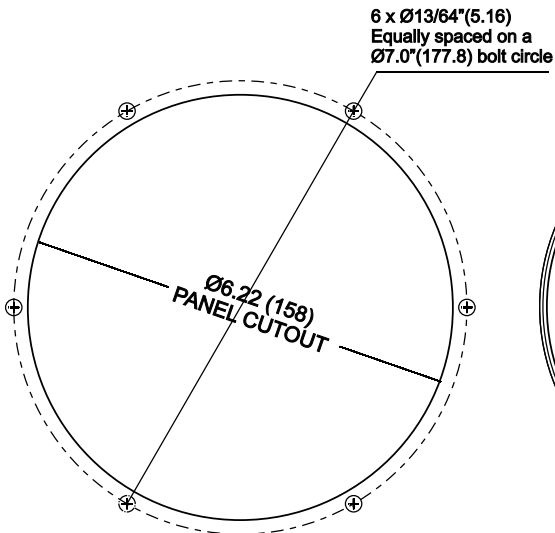

6.0" DIAL SIZE

PORTING DETAILS, PISTON INSTRUMENTS

BACK PORTING

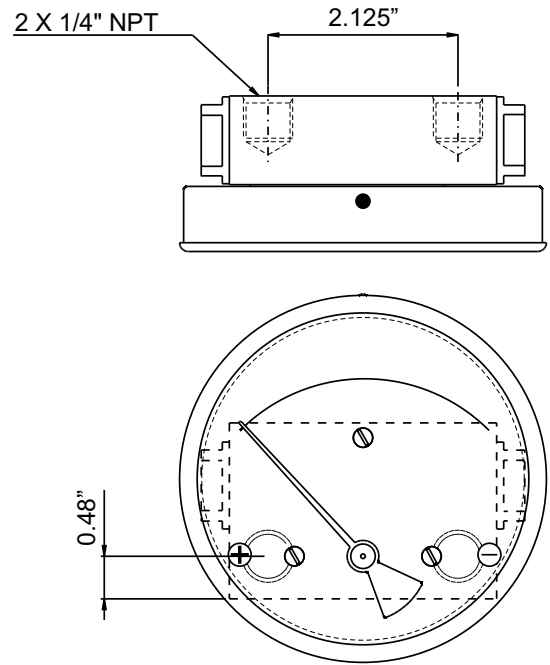

BOTTOM PORTING

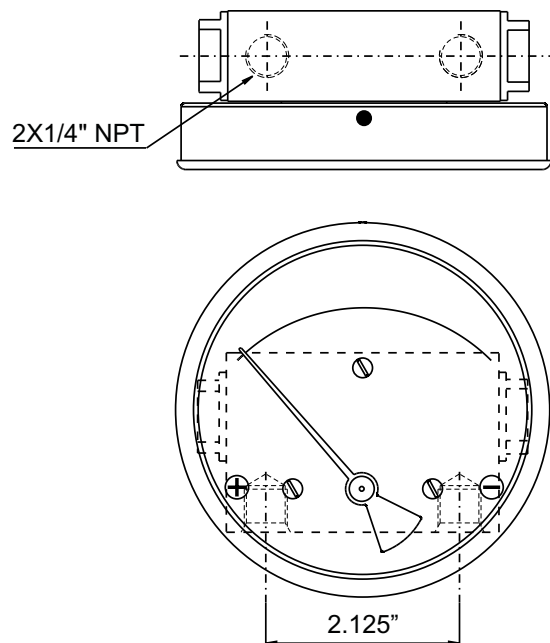

**BRACKET MOUNTING COMBINATIONS,
with and without switch**





Differential Pressure Plus Inc. has been designing and manufacturing filter indicators and differential pressure gauges for 25 years.



Web: DifferentialPressure.com

Email: info@dpgaugeusa.com

Phone: 203-481-2545

Address: 67-4 North Branford Road, Branford, CT, 06405